



CREATE Terrorism Modeling System (CTMS) and the Risk Analyst Workbench (RAW)

www.usc.edu/create

**Presentation to USC/UK Homeland Security Solutions Conference
September 8, 2005**

**Randolph W. Hall, Michael Orosz
University of Southern California**



System of Tools to Address These Problems

- Portfolio Allocation/Budgeting
- Programmatic Investments and Policies
- Targeted Investments
- Acting on Intelligence

System of Tools and Methods,
Adaptable to All Risks



CREATE Terrorism Modeling System (CTMS)

1. Structured problem characterization
2. Staircase model of terrorism intervention
3. Four-step modeling system
4. Terrorism Magnitude Scale
5. Integrated family of software tools



1. Structured Characterization: Framing the Question

- A. Threat
- B. Terrorism outcomes
- C. Counter-measures
- D. Correspondence of counter-measures to threats



2. Staircase Model of Intervention

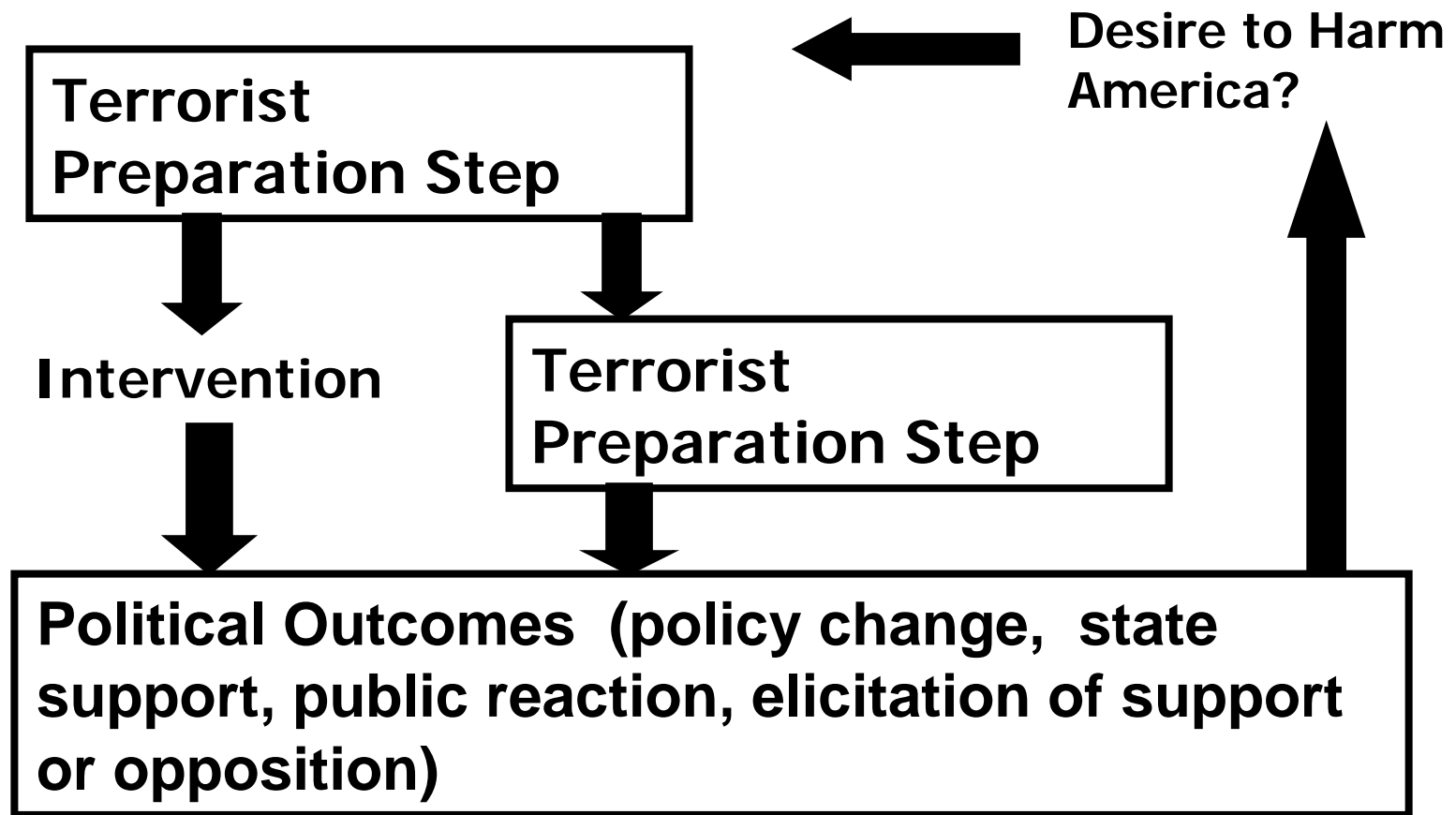

3. Four-Step Modeling System

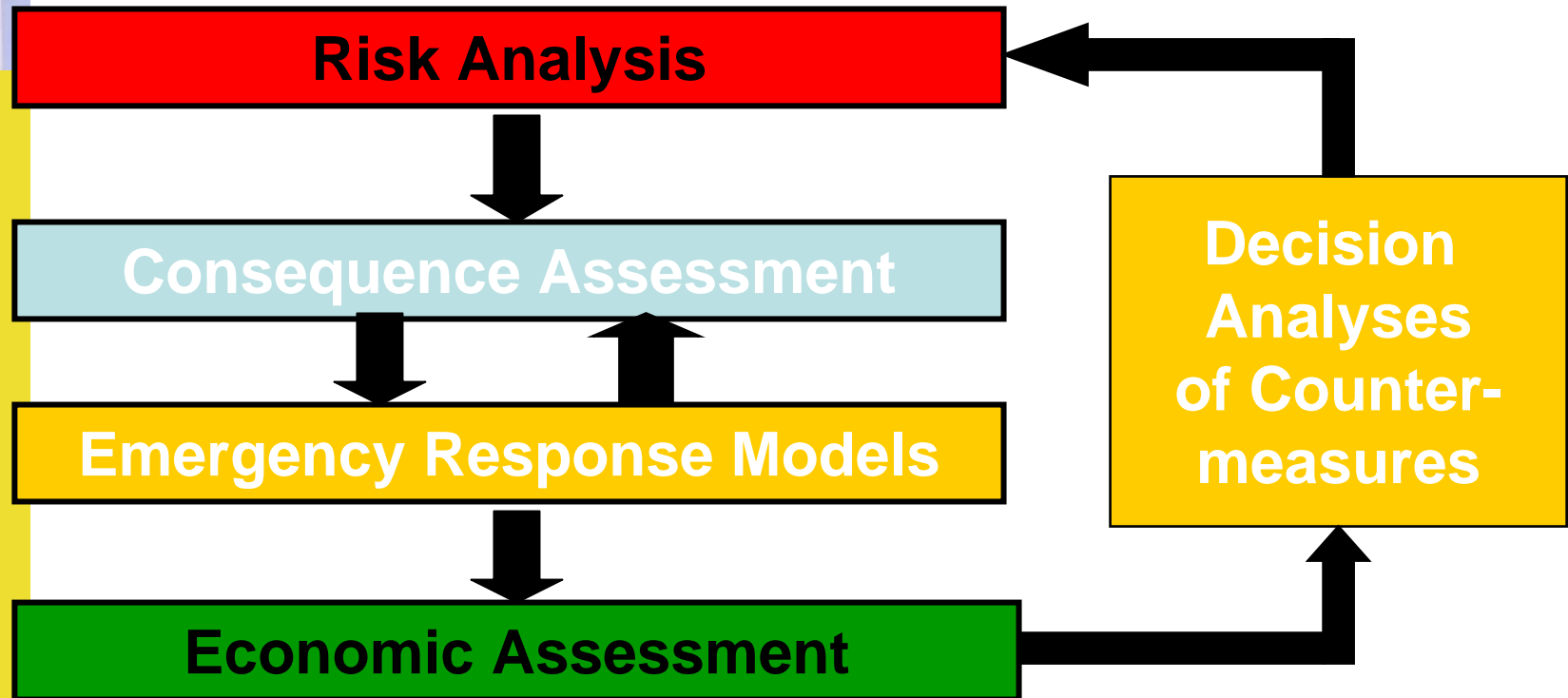

4. Event Magnitude Scale

- Enable order of magnitude comparisons
- Consider three key attributes: human, financial, symbolic
- Provide familiar reference point
- Solution: base 10 logarithmic scale, with maximum of 8
- New Orleans, WTC both likely a level 6 event by the scale



5. Integrated Software Tool: Risk Analyst Workbench (RAW/ISI)

1. Structured Problem Formulation
2. Guided Assessment of Threat Magnitude (scaling for each attribute)
3. Association of Counter-Measures with Threats – Guided Solution Generation
4. Ability to Call Analytical Tools or Data Sets to Support Analysis
5. Forced Consideration of Options and Outcomes



Risk Analyst Workbench (RAW): Features

- Distributed software environment
- Integration of risk assessment models, presentation tools, and data
- Collaborative decision environment
- Standardize scenario definition
- Built-in redundancy
- Secure dissemination of results
- Real-time data monitoring
- “What-if” support



Risk Analysis Workbench

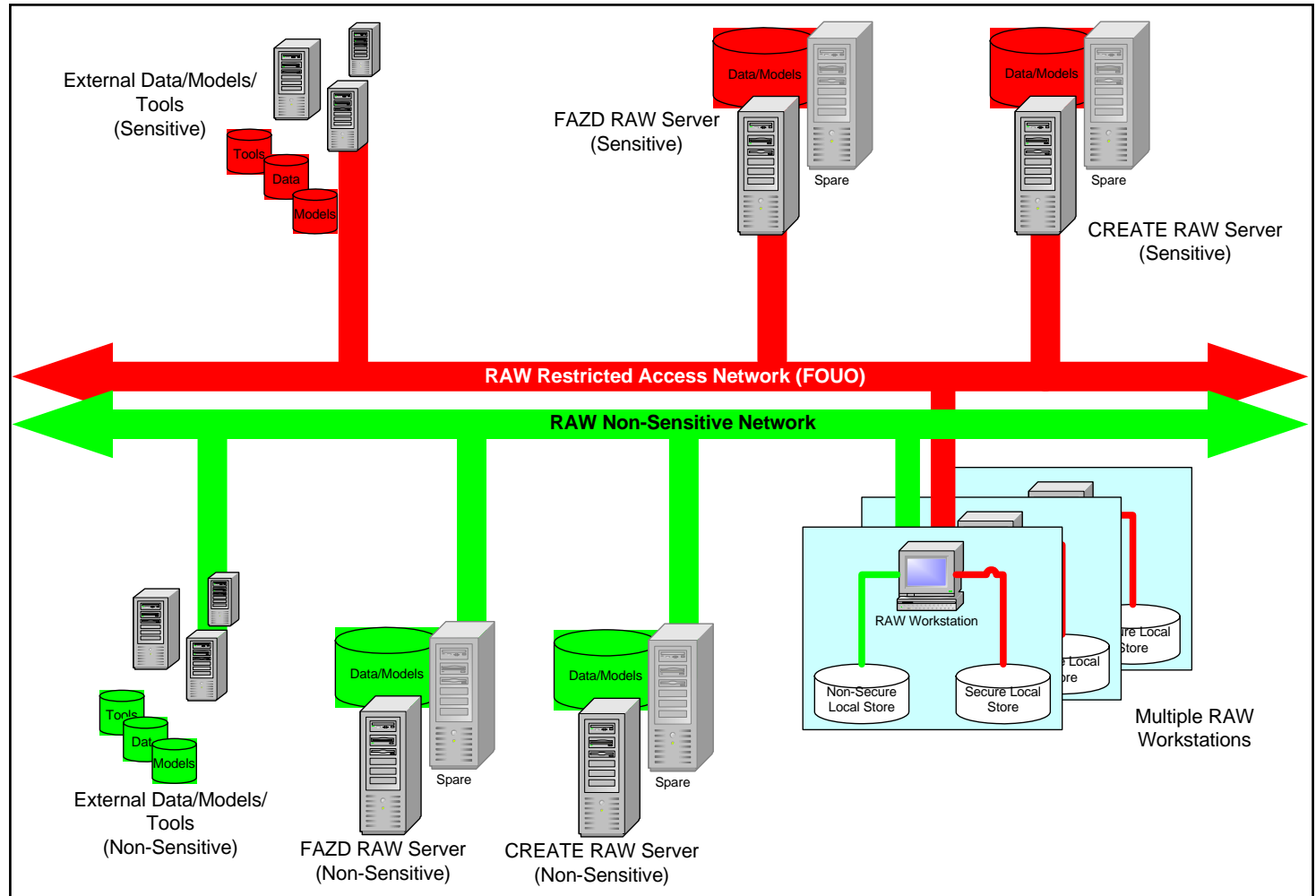

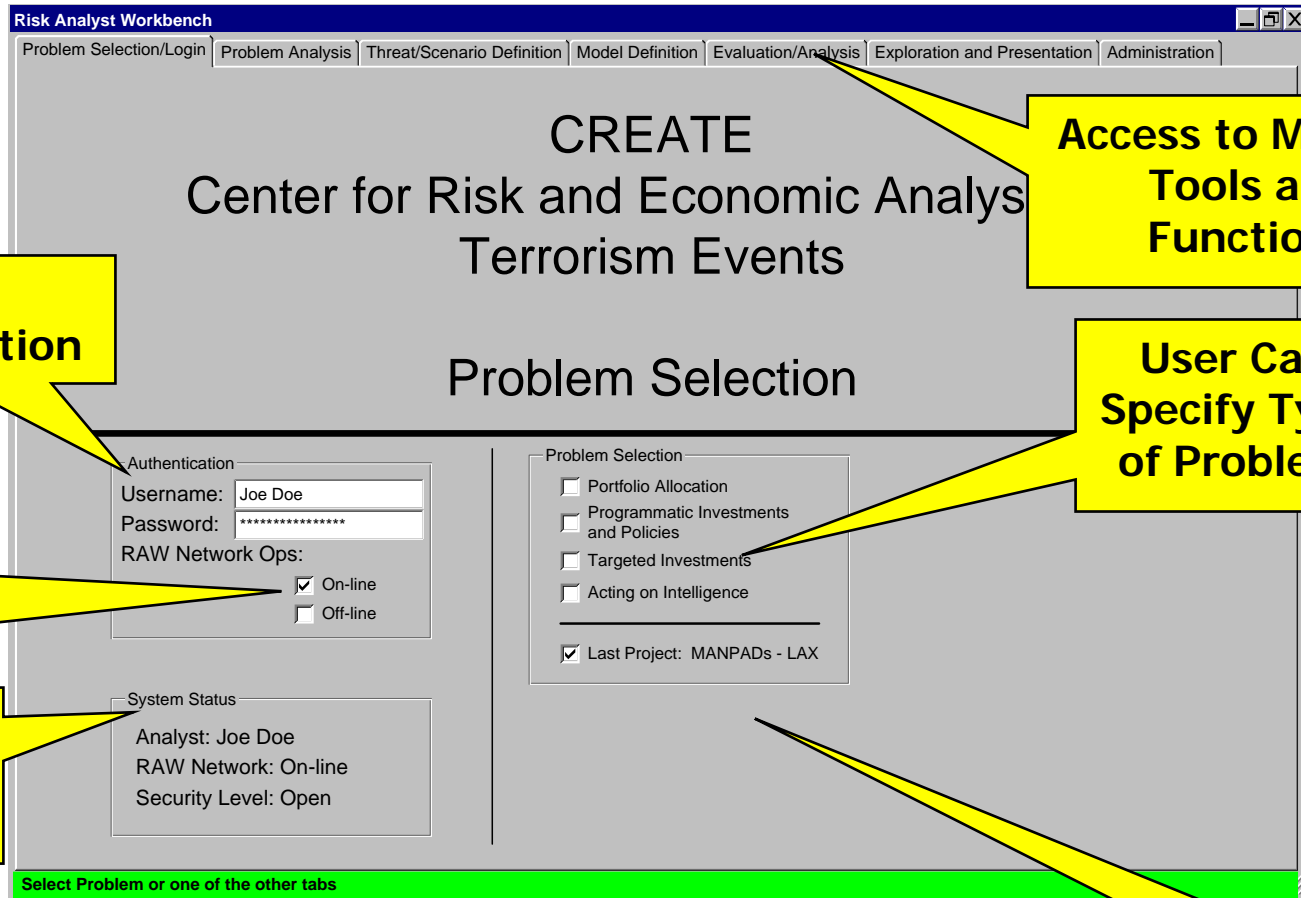

Risk Analyst Workbench

Problem Selection/Login | Problem Analysis | Threat/Scenario Definition | Model Definition | Evaluation/Analysis | Exploration and Presentation | Administration

CREATE
Center for Risk and Economic Analysis
Terrorism Events

Problem Selection

Authentication

Username: Joe Doe
Password: *****

RAW Network Ops:

On-line
 Off-line

System Status

Analyst: Joe Doe
RAW Network: On-line
Security Level: Open

Problem Selection

Portfolio Allocation
 Programmatic Investments and Policies
 Targeted Investments
 Acting on Intelligence

Last Project: MANPADS - LAX

Select Problem or one of the other tabs

Access to Multiple Tools and Functions

User Authentication

User Can Specify Type of Problem

User Can Specify On or Off-line

Current Session Status

User Can Open Previous Problem



Scenario Definition

Access to Multiple Tools and Functions

Risk Analyst Workbench

Problem Selection/Login | Problem Analysis | Threat/Scenario Definition | Model Definition | Evaluation/Analysis | Exploration/Presentation | Administration

Scenario Name: MANPAD CACE 13

Text Description (Narrative):
Determine probability and consequences of a successful MANPAD attack against an commercial jetliner near a major airport

The Process: Scenario Definition Flow

```

    graph LR
      1[Define Target] --> 2[Define Weapon]
      2 --> 3[Define Adversaries]
      3 --> 4[Define Counter-Measure (if used)]
      4 --> 5[Define Consequence (if used)]
  
```

1 Target
Location: Dallas/Ft Worth [Map]
Coordinates: 34N - 120W

2 Weapon
Type: SA-7
Location: Inside fence parameter

3 Adversaries
Number 3

Name	Location	Role	Experience
Suspect 1	Houston	Leader	Iraqi military
Suspect 2	Waco	Trigger	Al Queda training
Suspect 3	Waco	Protection	Unknown

4 Counter-Measures
 Part of Scenario

Type	Location	When Deployed	Costs
Flares	Aircraft	One second after detection	\$1M/Aircraft
Chaff	Aircraft	One second after detection	\$750K/Aircraft

5 Consequence
 Part of Scenario

- Aircraft brought down
- Aircraft damaged - forced to land

SAVE AS SAVE CANCEL

Edit Threat/Scenario definition User: Joe Doe RAW Network On-line Security: Open

Scenario Definition Process

Current Session Status



Detailed Specifications

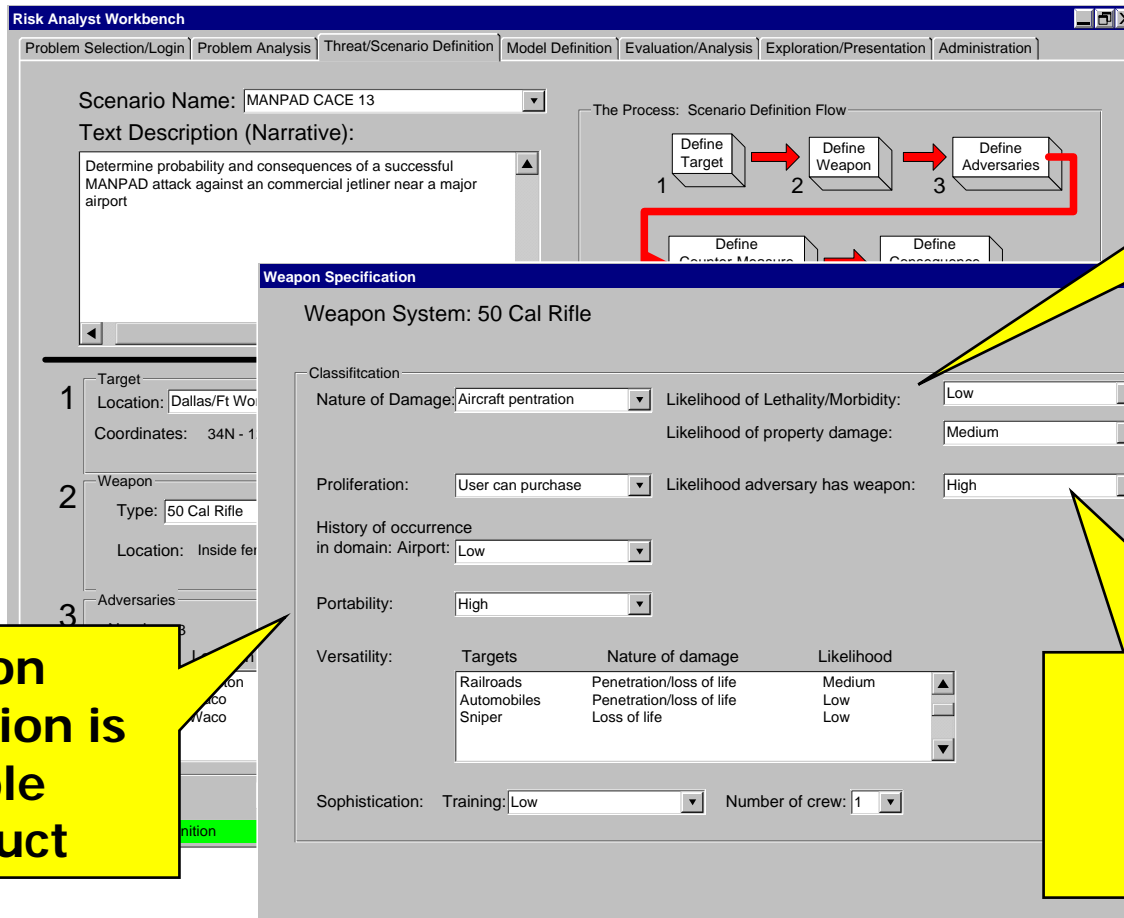

Risk Analyst Workbench

Problem Selection/Login | Problem Analysis | Threat/Scenario Definition | Model Definition | Evaluation/Analysis | Exploration/Presentation | Administration

Scenario Name: MANPAD CACE 13

Text Description (Narrative): Determine probability and consequences of a successful MANPAD attack against an commercial jetliner near a major airport

The Process: Scenario Definition Flow

```

    graph LR
      1[Define Target] --> 2[Define Weapon]
      2 --> 3[Define Adversaries]
      3 --> 4[Define Counter Measures]
      4 --> 5[Define Consequences]
  
```

Weapon Specification

Weapon System: 50 Cal Rifle

Classification

Nature of Damage: Aircraft penetration | Likelihood of Lethality/Morbidity: Low | Likelihood of property damage: Medium

Proliferation: User can purchase | Likelihood adversary has weapon: High

History of occurrence in domain: Airport: Low

Portability: High

Versatility:

Targets	Nature of damage	Likelihood
Railroads	Penetration/loss of life	Medium
Automobiles	Penetration/loss of life	Low
Sniper	Loss of life	Low

Sophistication: Training: Low | Number of crew: 1

Estimate of impact from weapon

Estimate, likelihood adversary has weapon

Weapon specification is possible byproduct



Spatial Data

User selects target location via CREATE GIS interface

CREATE GIS

Risk Analyst Workbench

Problem Selection/Login | Problem Analysis | Threat/Scenario Definition | Model Definition | Evaluation/Analysis | Exploration/Presentation | Administration

Scenario Name: MANPAD CACE 13

Text Description (Narrative): Determine probability and consequences of a successful MANPAD attack against an commercial jetliner near a major airport

The Process: Scenario Definition Flow

```

    graph LR
      1[Define Target] --> 2[Define Weapon]
      2 --> 3[Define Adversaries]
      3 --> 4[Define Counter-Measure (if used)]
      4 --> 5[Define Consequence (if used)]
  
```

1 Target
Location: Dallas/Ft Worth
Coordinates: 34N - 120W

2 Weapon
Type: SA-7
Location: Inside fence param

3 Adversaries
Number 3

Name	Location	Role
Suspect 1	Houston	Leade
Suspect 2	Waco	Trigge
Suspect 3	Waco	Prote

SAVE A...

Edit Threat/Scenario definition

OpenMap(tm)

1:50,000,000

- World Cities
- UTM Grid
- Day/Night Shading
- Date & Time
- Drawing Layer
- Distance Layer
- Graticule
- Terrain Tools
- Demo Layer
- DTED Coverage
- Water
- DTED

Lat, Lon (42.21, -70.83) - x, y (291,220)

Boston



“What-if” Analysis

Sliders:
Adjust
Parameters

Previous
“What-if”
Runs

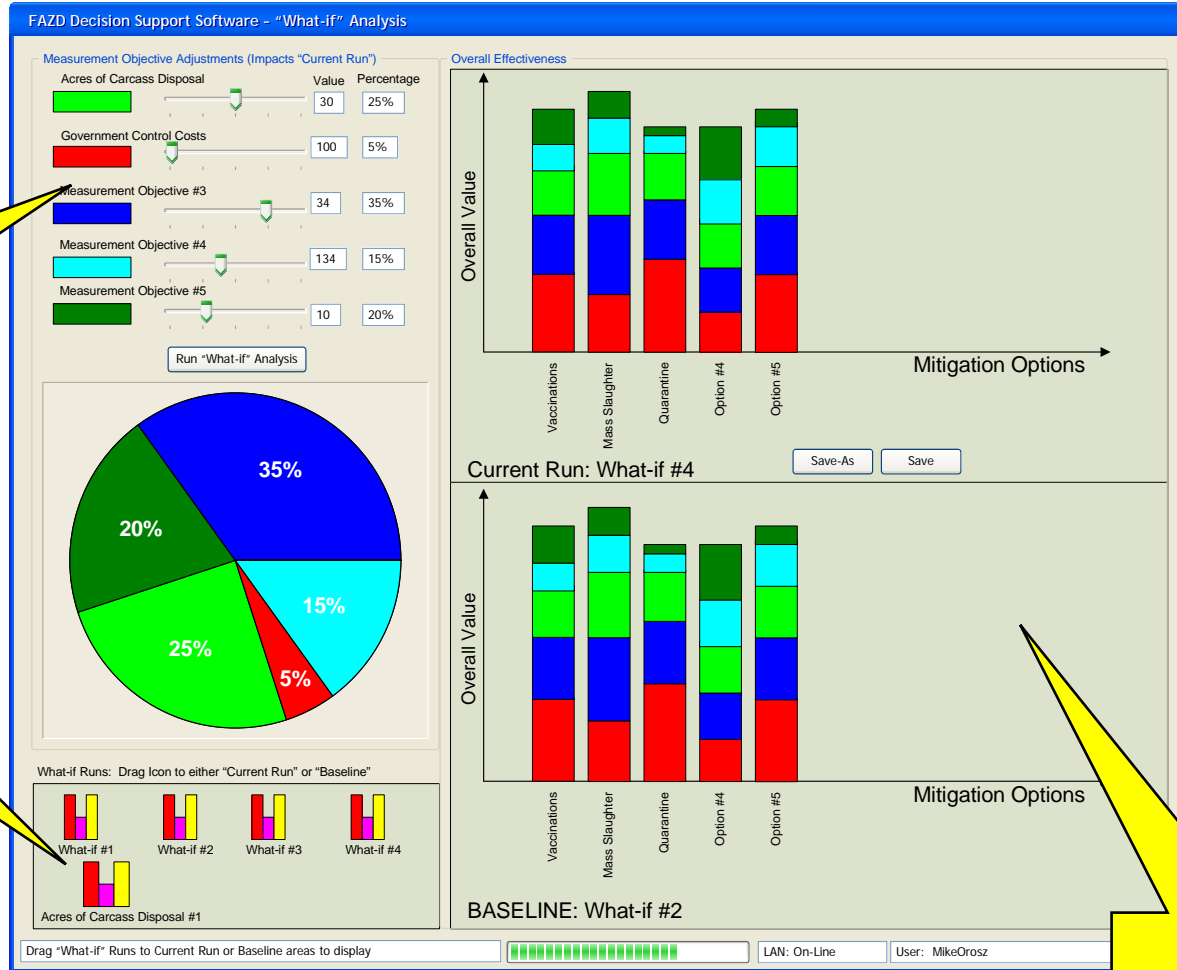

“What-if”
Comparisons



Cross Center Collaboration – FAZD Center

- National Center for Foreign Animal and Zoonotic Diseases Defense (FAZD)
- Under contract with Texas A&M FAZD to extend RAW
 - To aid in FAZD risk analysis
 - Develop decision-support tools
 - Enhanced risk modeling software
 - To promote collaboration with CREATE
- First opportunity to foster cross-center collaboration
- Preliminary design completed in August



Status

- CREATE Requirements and detailed system design completed
 - User Interface (UI) mock-ups
- CREATE RAW prototype software development started
- Preliminary FAZD requirements and system design completed

